



(12) **United States Patent**
Dyson, Jr. et al.

(10) **Patent No.:** **US 9,871,186 B1**
(45) **Date of Patent:** **Jan. 16, 2018**

(54) **MAGNETOSTRICTIVE ALTERNATOR**
(71) Applicant: **The United States of America as represented by the Administrator of the National Aeronautics and Space Administration, Washington, DC (US)**

(72) Inventors: **Rodger W. Dyson, Jr., Elyria, OH (US); Geoffrey A. Bruder, Parma Heights, OH (US)**

(73) Assignee: **The United States of America as Represented by the Administrator of National Aeronautics and Space Administration, Washington, DC (US)**

(*) Notice: Subject to any disclaimer, the term of this patent is extended or adjusted under 35 U.S.C. 154(b) by 444 days.

(21) Appl. No.: **13/916,797**
(22) Filed: **Jun. 13, 2013**

Related U.S. Application Data

(60) Provisional application No. 61/677,116, filed on Jul. 30, 2012.
(51) **Int. Cl.**
H01L 41/12 (2006.01)
H01L 41/113 (2006.01)
(52) **U.S. Cl.**
CPC **H01L 41/125** (2013.01); **H01L 41/113** (2013.01)

(58) **Field of Classification Search**
CPC H01L 41/113; H01L 41/1134; H01L 41/1136; H01L 41/1138
USPC 310/339
See application file for complete search history.

(56) **References Cited**
U.S. PATENT DOCUMENTS
6,150,752 A * 11/2000 Bishop B01J 19/10 310/328
2001/0035723 A1* 11/2001 Pelrine et al. 318/116
2010/0244457 A1* 9/2010 Bhat et al. 310/339
2013/0320804 A1* 12/2013 Symko et al. 310/306
* cited by examiner

Primary Examiner — Derek Rosenau
(74) *Attorney, Agent, or Firm* — Robert H. Earp, III

(57) **ABSTRACT**
A magnetostrictive alternator configured to convert pressure waves into electrical energy is provided. It should be appreciated that the magnetostrictive alternator may be combined in some embodiments with a Stirling engine to produce electrical power. The Stirling engine creates the oscillating pressure wave and the magnetostrictive alternator converts the pressure wave into electricity. In some embodiments, the magnetostrictive alternator may include aerogel material and magnetostrictive material. The aerogel material may be configured to convert a higher amplitude pressure wave into a lower amplitude pressure wave. The magnetostrictive material may be configured to generate an oscillating magnetic field when the magnetostrictive material is compressed by the lower amplitude pressure wave.

15 Claims, 2 Drawing Sheets

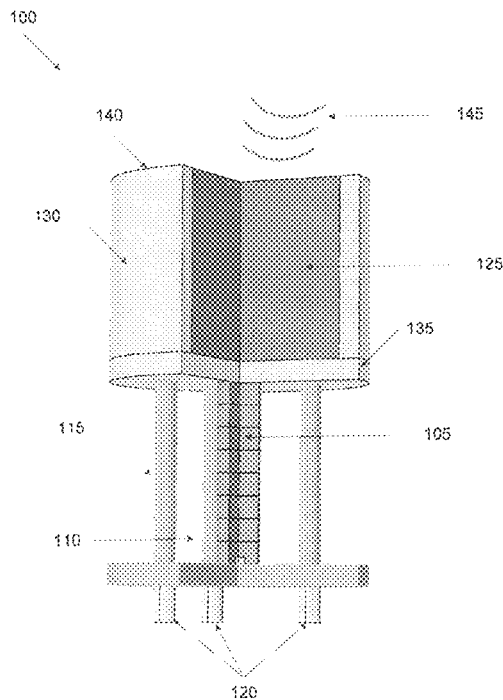

FIG. 1A

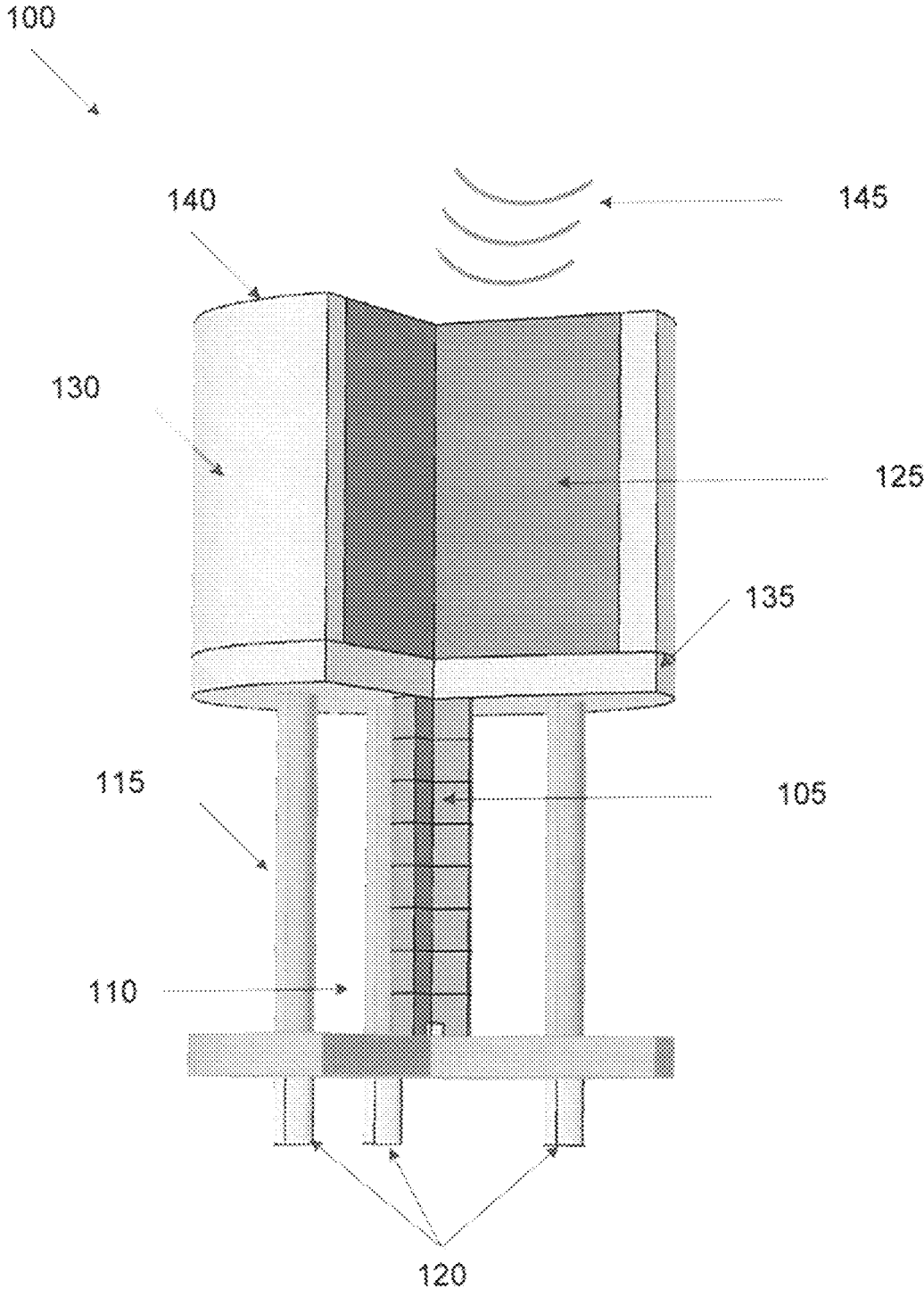
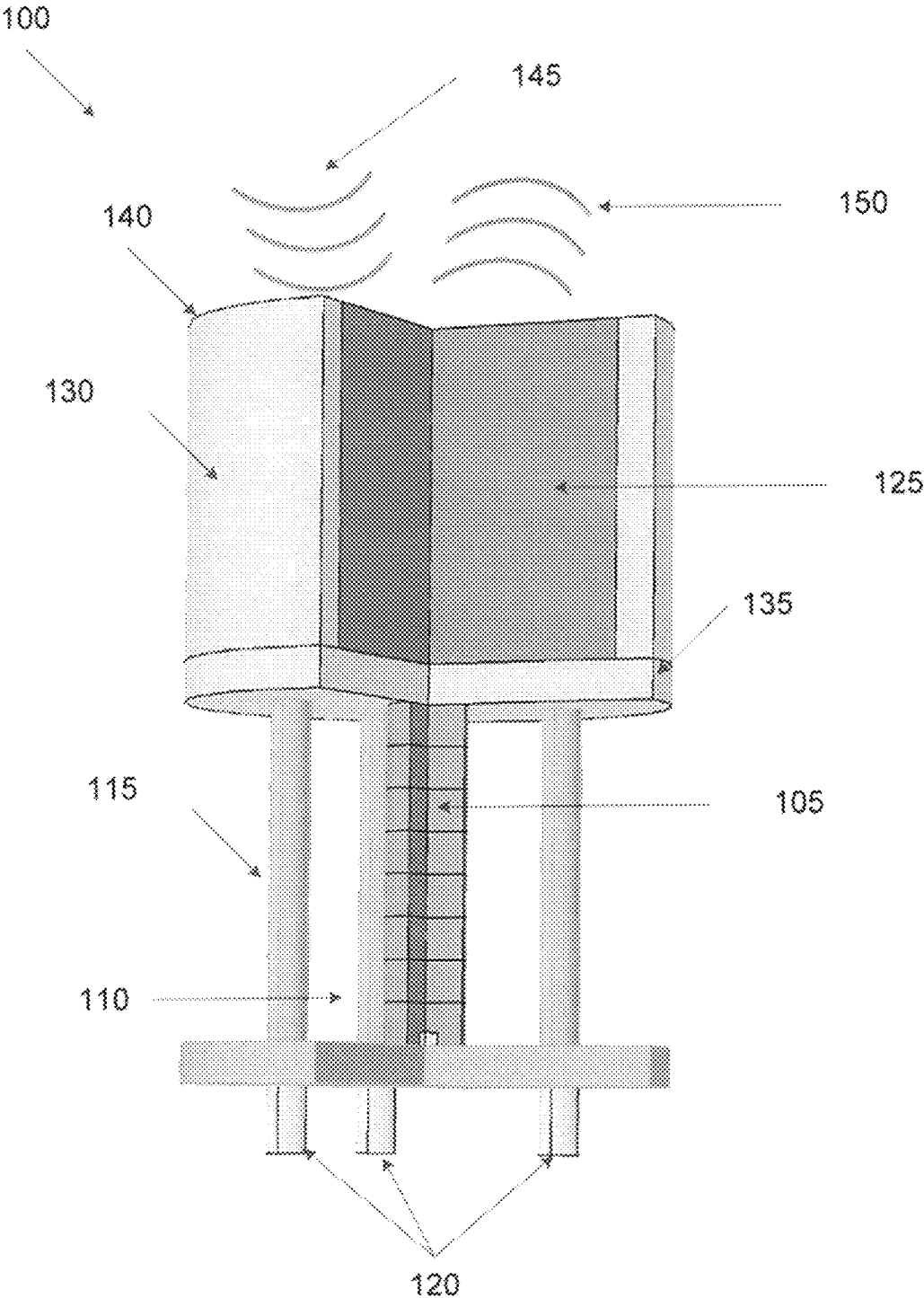

FIG. 1B



1

MAGNETOSTRICTIVE ALTERNATORCROSS REFERENCE TO RELATED
APPLICATIONS

This application is a non-provisional of, and claims priority to, U.S. Provisional Patent Application Ser. No. 61/677,116, filed Jul. 30, 2012, the subject matter of which is hereby incorporated by reference in its entirety.

ORIGIN OF THE INVENTION

The invention described herein was made in the performance of work under a NASA contract and is subject to the provisions of Section 305 of the National Aeronautics and Space Act of 1958, Public Law 85-568 (72 Stat. 435; 42 U.S.C. 2457).

FIELD

The present invention relates to alternators and, more particularly, to a magnetostrictive alternator configured to convert pressure waves into electrical energy.

BACKGROUND

Stirling engines use alternators, such as moving linear magnet alternators, to convert mechanical motion into electrical energy. For instance, conventional alternators use a piston that moves a magnet and/or coil, and the change in magnetic field induces a current in the coil to deliver electric power to the load. However, with the use of moving pistons, the frequency, efficiency, and maximum power output of the energy produced by such alternators is limited.

Accordingly, an improved alternator may be beneficial.

SUMMARY

Certain embodiments of the present invention may provide solutions to the problems and needs in the art that have not yet been fully identified, appreciated, or solved by current alternators. For instance, some embodiments of the present invention replace an oscillating linear alternator with an impedance and resonance matched magnetostrictive based transducer.

In one embodiment, an apparatus is provided. The apparatus includes aerogel material and magnetostrictive material. The aerogel material is configured to convert a higher amplitude pressure wave into a lower amplitude pressure wave. The magnetostrictive material is configured to generate an oscillating magnetic field when the magnetostrictive material is compressed by the lower amplitude pressure wave.

In another embodiment, an apparatus is provided. The apparatus includes an absorbing material and a compressing material. The absorbing material is configured to convert a higher amplitude pressure wave into a lower amplitude pressure wave. The compressing material is configured to generate an oscillating magnetic field when the compressing material is compressed by the lower amplitude pressure wave.

In yet another embodiment, an apparatus is provided. The apparatus includes an absorbing material and a piezoelectric material. The absorbing material is configured to convert a higher amplitude pressure wave into a lower amplitude pressure wave. The piezoelectric material is configured to

2

generate an oscillating electric field when the lower amplitude pressure wave is applied to the piezoelectric material.

BRIEF DESCRIPTION OF THE DRAWINGS

5

In order that the advantages of certain embodiments of the invention will be readily understood, a more particular description of the invention briefly described above will be rendered by reference to specific embodiments that are illustrated in the appended drawings. While it should be understood that these drawings depict only typical embodiments of the invention and are not therefore to be considered to be limiting of its scope, the invention will be described and explained with additional specificity and detail through the use of the accompanying drawings, in which:

FIG. 1A illustrates a magnetostrictive alternator, according to an embodiment of the present invention.

FIG. 1B illustrates a magnetostrictive resonator, according to an embodiment of the present invention.

10
15
20DETAILED DESCRIPTION OF THE
EMBODIMENTS

Some embodiments of the present invention pertain to a Stirling magnetostrictive alternator having stacked magnetostrictive material under a biased magnetic and stress induced compression with continuous gradient impedance matching material. Alternating compression and expansion of the magnetostrictive material may be configured to create an alternating magnetic field to induce an electric current in a coil that is wrapped around the magnetostrictive material. This allows production of electrical power from the acoustic pressure wave.

FIG. 1A illustrates a magnetostrictive alternator **100**, according to an embodiment of the present invention. Magnetostrictive alternator (hereinafter "alternator") **100** may be operated as an electrical power source that is connected to, and provides power to, a Stirling engine. As shown in FIG. 1A, alternator **100** includes a stack of magnetostrictive material **105**, such as Terfenol-D™, Nickel, Nitinol or Galfenol, or any material that would be appreciated by a person of ordinary skill in the art. In other embodiments, piezoelectric material, or any type of material that can be compressed by a pressure force, may be used depending on the configuration of alternator **100**. In certain embodiments, the stack of magnetostrictive material **105** is wrapped in coils. The coils may be composed of copper, aluminum, or any electrically conductive material that can be enveloped by an insulating material and wound into a coil. It should be appreciated that if piezoelectric material is used, then a coil may not be wrapped around the piezoelectric material.

It should be appreciated that in some embodiments, a pre-stress (or compression) is applied to magnetostrictive material **105**. This allows for an increase in power output. To achieve an increase in power output, pre-stress permanent magnets **110** and pre-stress bolts **115** are used to compress, or increase stress on, the stack of magnetostrictive material **105** to an ideal location in terms of the linear range of magnetostrictive material **105** for producing an increase in electrical power output.

Pre-stress permanent magnets **110** in this embodiment are configured to provide a magnetic field causing magnetostrictive material **105** to remain in a compressed state. In some embodiments, secondary pre-stress coils may be used for this purpose, but this may require a separate power source to produce the magnetic field. The pre-stress effect maximizes the efficiency of magnetostrictive material **105**. It

should be noted that without pre-stress permanent magnets **110**, the power output may be reduced.

Stated differently, magnetostrictive material **105** is compressed to allow magnetostrictive material **105** to include some force. In other words, a predefined amount of pre-stress is applied to magnetostrictive material **105**. Thus, when a fairly high amplitude pressure wave **145**, which is produced by a Stirling engine (or another acoustic source), reaches alternator **100**, pressure wave **145** causes further compression of magnetostrictive material **105** to generate an increase in electrical power output. In certain embodiments, pressure wave **105** may be an oscillating pressure wave. Because pressure wave **105** may move helium or other atoms approximately 5 mm in either direction and to prevent pressure wave **105** from reflecting off of magnetostrictive material **105**, a varying density aerogel **125** is utilized for impedance matching with magnetostrictive material **105**. It should be noted that any type of absorbing material, which can impedance match, may be used. This allows energy from pressure wave **145** to be absorbed into magnetostrictive material **105**, creating a greater output of electrical power. It should be appreciated that other impedance matching materials, such as steel rods, may be used instead of aerogel. However, this depends on the Stirling engine operating parameters.

Certain embodiments may include a protective diaphragm **140** to help keep aerogel **125** from breaking up. An impedance layer support **130** surrounds aerogel **125** to hold aerogel **125** in place.

As mentioned above, aerogel **125** may be configured to absorb pressure wave **145** to avoid reflection, and change a high amplitude of pressure wave **145** to a lower (or smaller) amplitude pressure wave (not shown) without losing the energy in the pressure wave, allowing the energy to compress magnetostrictive material **105** efficiently. In order to translate the force from aerogel **125** to magnetostrictive material **105**, a force plate **135** is utilized.

Once the mechanical energy in aerogel **125** reaches magnetostrictive material **105**, magnetostrictive material **105** is compressed via force plate **135** at a certain frequency (e.g., approximately 100 times per second), producing an oscillating magnetic field. The magnetic field causes the state of the coil, which is wrapped around magnetostrictive material **105**, to move to a varying magnetic flux environment. Because the coil is in a varying magnetic flux environment, an electrical field (e.g., a current) is induced in the coil to produce electrical power.

Located near magnetostrictive material **105** are Bellville washers **120**. Bellville washers **120** are configured to prevent alternator **100** from being over-constrained, allowing force plate **135** to move.

It should be appreciated that alternator **100** does not require a piston to be moving in order to produce electrical power as the parts in alternator **100** are compressing. Further, if a moving-part Stirling engine is replaced with a non-moving-part Stirling engine, then a generator having no moving parts can be achieved. It should also be appreciated that alternator **100** may be scalable, such that multiple alternators can be stacked upon each other. Alternator **100** may also vary in size depending on the frequency desired.

As shown in FIG. 1B, alternator **100** may also be used as a resonator. In such an embodiment, a large amplitude wave **145** that is received by aerogel **125** or steel rod (not shown), and is reduced to a lower amplitude wave (not shown). The lower amplitude wave has a high force that collides with force plate **135**, causing magnetostrictive material **105** to

compress. The compression of magnetostrictive material **105** allows electricity to be generated.

However, because not all of the compression is converted to electricity, the unconverted amount of compression is configured to bounce. This may cause magnetostrictive material **105** to re-expand, creating a low amplitude wave (not shown). The low amplitude wave is configured to travel to aerogel **135** and is converted to a high amplitude wave **150**. High amplitude wave **150** is then transmitted to the Stirling engine to provide resonance.

Some embodiments of the present invention pertain to an oscillating pressure wave that is converted into a low amplitude pressure wave to compress the magnetostrictive material in order to generate electrical power. As a result, bearings, lubrication, etc., are not required, lowering operational cost. The alternator described herein may also be used for generating power in vehicles (air, sea, land, or space), as well as buildings. It should be appreciated that the alternator described herein may produce electrical power, create a resonance for the Stirling engine, provide control of the Stirling engine, and create un-amplified pressure wave in the Stirling engine that can be amplified at a later time.

It will be readily understood that the components of the invention, as generally described and illustrated in the figures herein, may be arranged and designed in a wide variety of different configurations. Thus, the detailed description of the embodiments is not intended to limit the scope of the invention as claimed, but is merely representative of selected embodiments of the invention.

The features, structures, or characteristics of the invention described throughout this specification may be combined in any suitable manner in one or more embodiments. For example, the usage of "certain embodiments," "some embodiments," or other similar language, throughout this specification refers to the fact that a particular feature, structure, or characteristic described in connection with an embodiment may be included in at least one embodiment of the invention. Thus, appearances of the phrases "in certain embodiments," "in some embodiments," "in other embodiments," or other similar language, throughout this specification do not necessarily all refer to the same embodiment or group of embodiments, and the described features, structures, or characteristics may be combined in any suitable manner in one or more embodiments.

One having ordinary skill in the art will readily understand that the invention as discussed above may be practiced with steps in a different order, and/or with hardware elements in configurations that are different than those which are disclosed. Therefore, although the invention has been described based upon these preferred embodiments, it would be apparent to those of skill in the art that certain modifications, variations, and alternative constructions would be apparent, while remaining within the spirit and scope of the invention. In order to determine the metes and bounds of the invention, therefore, reference should be made to the appended claims.

The invention claimed is:

1. An apparatus, comprising:

an aerogel material configured to continuously transition from a lower impedance to a higher impedance in one direction, and therefore opposite in the opposite direction, and configured to permit the transmission of an acoustic wave therethrough; and
magnetostrictive material configured to generate an oscillating magnetic field when the magnetostrictive material is compressed by the acoustic wave transmitted through the aerogel material.

5

2. The apparatus of claim 1, wherein the aerogel material is configured to receive the acoustic wave from a Stirling engine.

3. The apparatus of claim 1, further comprising:
a force plate configured to translate force generated by the acoustic wave into the magnetostrictive material.

4. The apparatus of claim 1, further comprising:
a plurality of pre-stressed bolts configured to apply a predetermined amount of compression to the magnetostrictive material; and
a plurality of pre-stress permanent magnets configured to generate a magnetic field to cause the magnetostrictive material to remain in a compressed state.

5. The apparatus of claim 1, further comprising:
a coil configured to produce electrical power when the magnetostrictive material generates the oscillating magnetic field.

6. The apparatus of claim 5, wherein the coil is configured to surround the magnetostrictive material.

7. The apparatus of claim 1, further comprising:
a protective diaphragm configured to prevent the aerogel from breaking; and
an impedance layer support surrounding the aerogel, and configured to maintain a position of the aerogel.

8. An apparatus, comprising:
a wave absorbing impedance matching material configured to continuously transition from a lower impedance to a higher impedance in one direction, and therefore opposite in the opposite direction, and configured to permit the transmission of an acoustic wave there-through; and

6

a compressing material configured to generate an oscillating magnetic field when the compressing material is compressed by the acoustic wave transmitted through the wave absorbing impedance matching material.

9. The apparatus of claim 8, wherein the absorbing material is configured to absorb the acoustic wave from a Stirling engine to prevent reflection.

10. The apparatus of claim 8, further comprising:
a force plate configured to translate force generated by the acoustic wave into the compressing material.

11. The apparatus of claim 8, further comprising:
a plurality of pre-stressed bolts configured to apply a predetermined amount of compression to the compressing material; and
a plurality of pre-stress permanent magnets configured to generate a magnetic field to cause the compressing material to remain in a compressed state.

12. The apparatus of claim 8, further comprising:
a coil configured to produce electrical power when the compressing material generates the oscillating magnetic field.

13. The apparatus of claim 12, wherein the coil is configured to surround the compressing material.

14. The apparatus of claim 8, further comprising:
a protective diaphragm configured to prevent the absorbing material from breaking; and
an impedance layer support surrounding the absorbing material, and configured to maintain a position of the absorbing material.

15. The apparatus of claim 8, wherein the absorbing material comprises aerogel or a steel bar.

* * * * *